



Maximizing Network Capacity, Reach and Value
Over land, under sea, worldwide

Xtera Communications, Inc.

Getting More out of Existing Repeated Submarine Cables Systems

Tony Frisch – March 2011

The full 25 years



- Submerged plant is very reliable
- Early systems are well designed
- Initial design capacity is usually not enough for 25 years
- Low capacity is expensive to maintain
- Technology now permits significantly increased capacity
- Allows newer traffic types: Gigabit Ethernet, OTN ...
- Newer terminal equipment is simpler to use, easier to maintain
- Greener than old equipment



- Terminal is the easiest thing to change

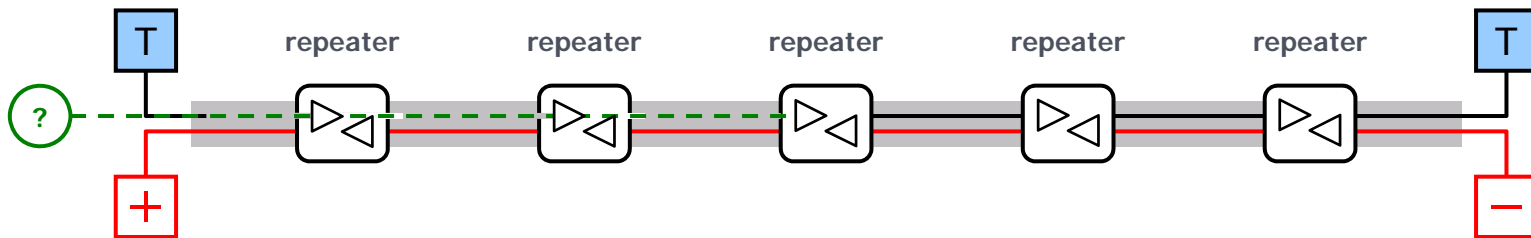

- Most technology / remarks applicable to unrepeated systems



- Changing amplifiers not yet tried ...

Overlay Upgrades

- The old terminal can remain

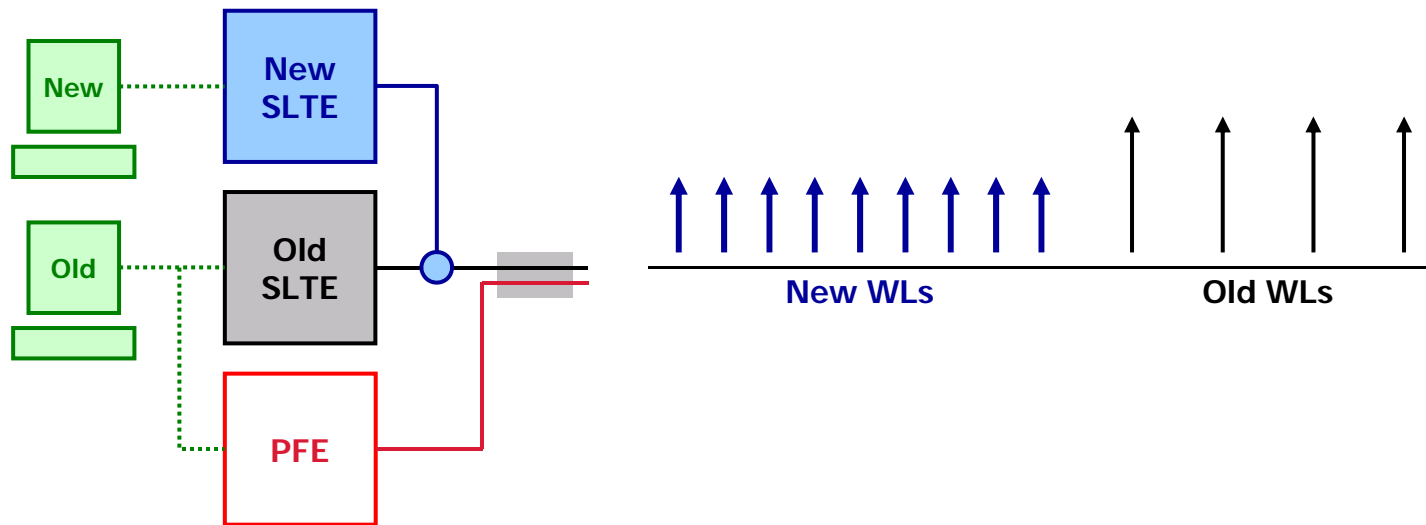

- Separate management systems
- Can often keep old wet-plant supervision
- Signal levels, control schemes etc. need to be considered

New cable

- Desk-top survey
- RFI/RFP
- Assessment
- Obtain several permits
- Marine survey
- Negotiate contracts
- Marine installation
- PFE and Terminal installation
Commissioning and Testing

- + Huge potential capacity
- Takes time
- Quite expensive

Terminal Upgrade





- RFI/RFP
- Assessment
- Negotiate contracts
- Terminal installation
Commissioning and Testing

- Limited capacity
- + Quick & Simple
- + Not expensive

When is a terminal upgrade not a good idea

- If a very large capacity is needed
- If the system uses regenerators
- If the system is full and even a short outage is unacceptable
- If the submerged system is unreliable

Submarine Line Evolution

- 1. All DSF  1 channel
- 2. NZ-DSF  WDM, more power
- 3. LEAF  reduces non-linear effects
- 4. +D/-D  even better
- 5. All +D  the next step? BW near to limit?



Routes to higher capacity

- More wavelengths = Lower power per WL

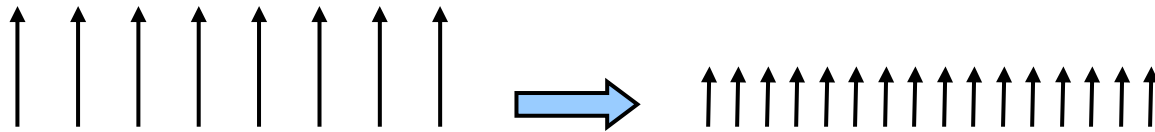

- Higher line-rate = shorter, lower energy, pulses



- Need TX improvements $2x = 3\text{dB}$, $4x = 6\text{ dB}$, $10x = 10\text{ dB}$
- Forward Error Correction FEC
- Phase Shift Modulation PSK, DPSK, QPSK ...
- Two polarisations
- Unused margin

Budget – existing channels

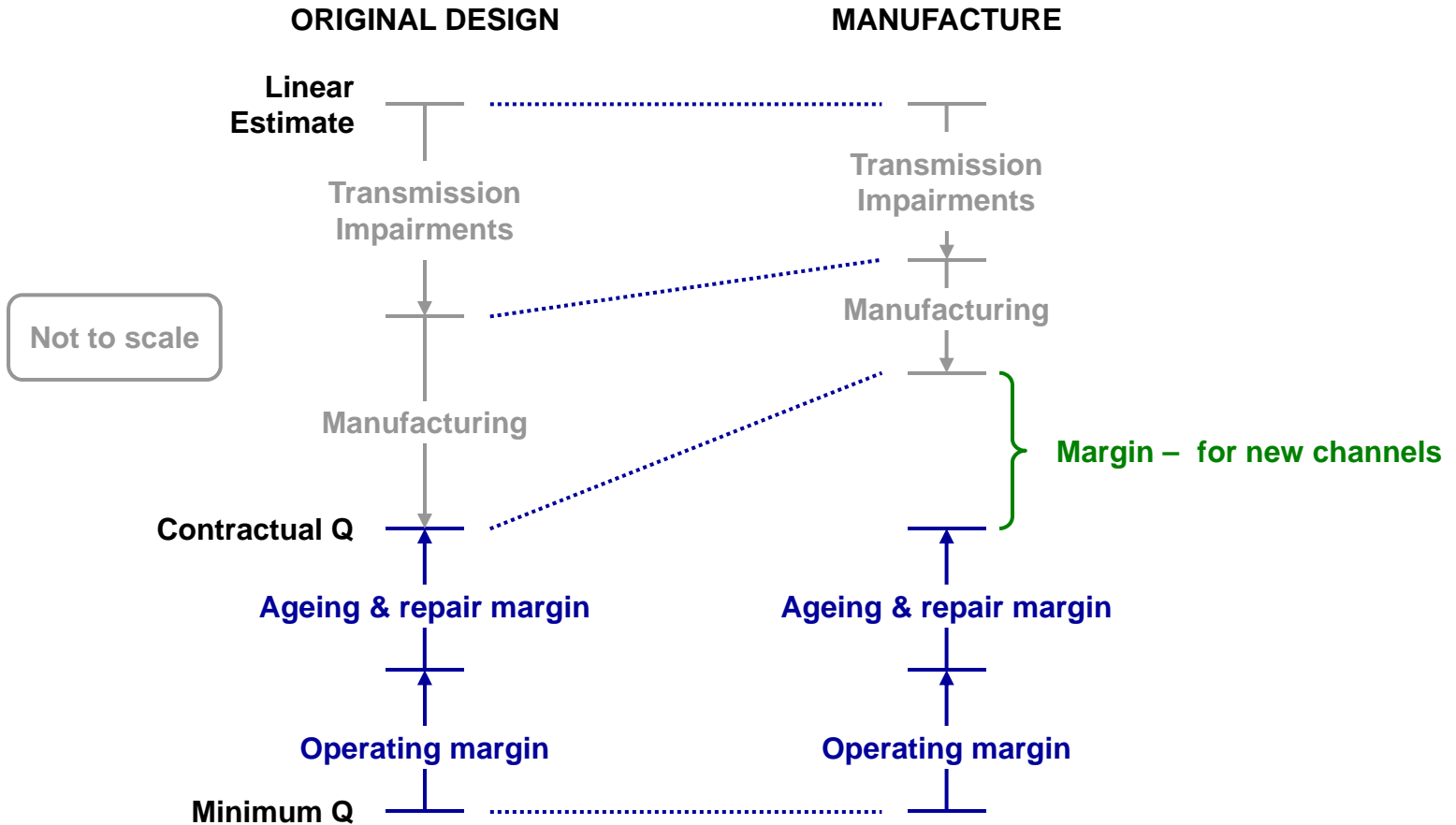

Budget – new channels

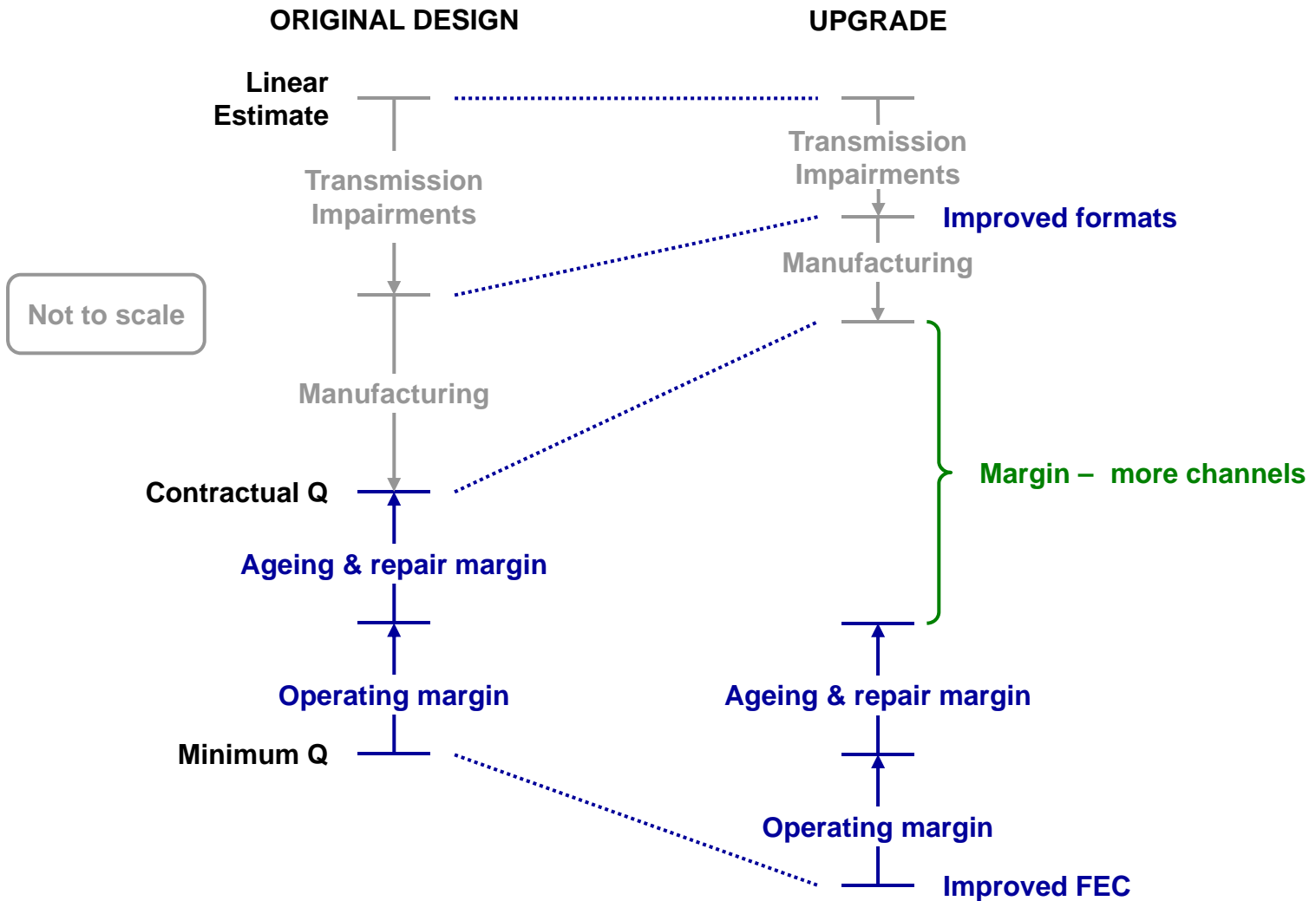

Example: Columbus 3

- US – Portugal, Spain and Italy

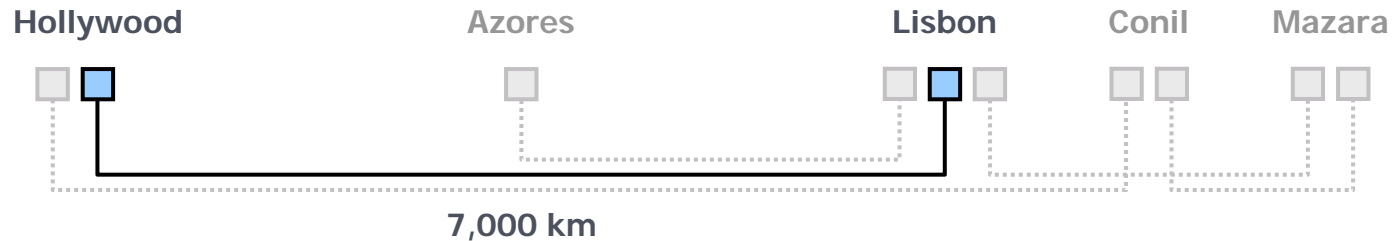

- Originally designed for $8 \times 2.5G = 20G$
- Upgraded to $8 \times 20G = 160G$
- Proven capacity $16 \times 20G = 320G$ 16x
- Using new technology
Possible capacity $16 \times 40G = 640G ?$

Example: Channel Plans

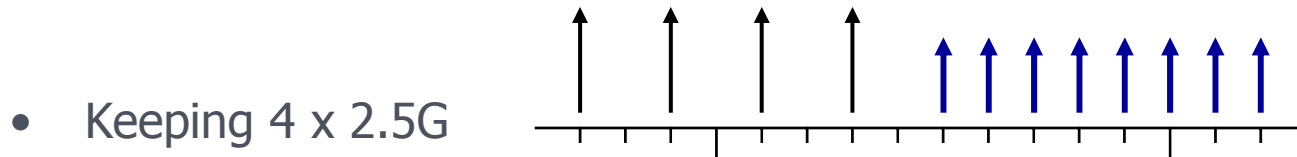
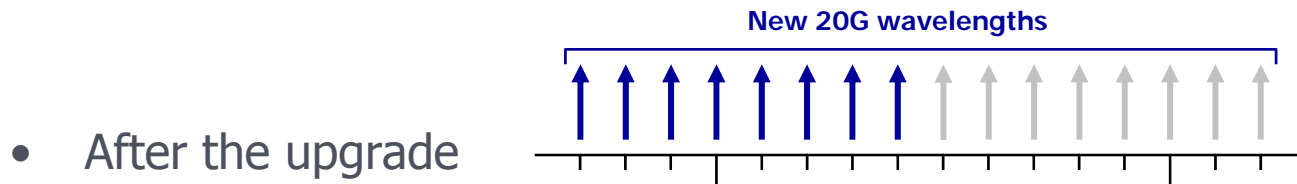
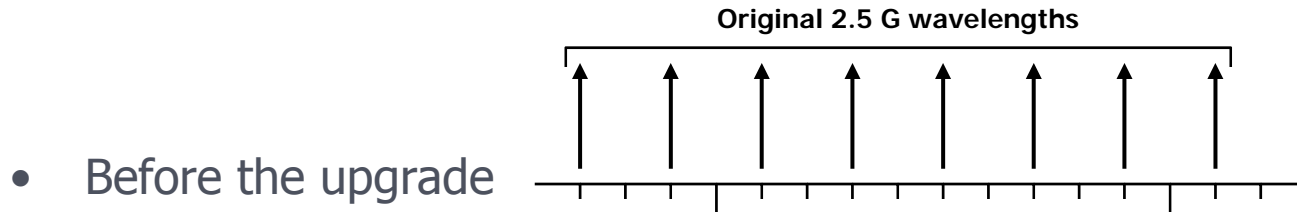

- Ultimate capacity would be reduced by 140G



Assessing upgrade potential

- Simulation OK if all inputs are known
- Measurement More certain, but disruptive and takes time
Requires careful interpretation

- Performance varies across the band
- Must check at several wavelengths
- Critical to get and keep correct power levels

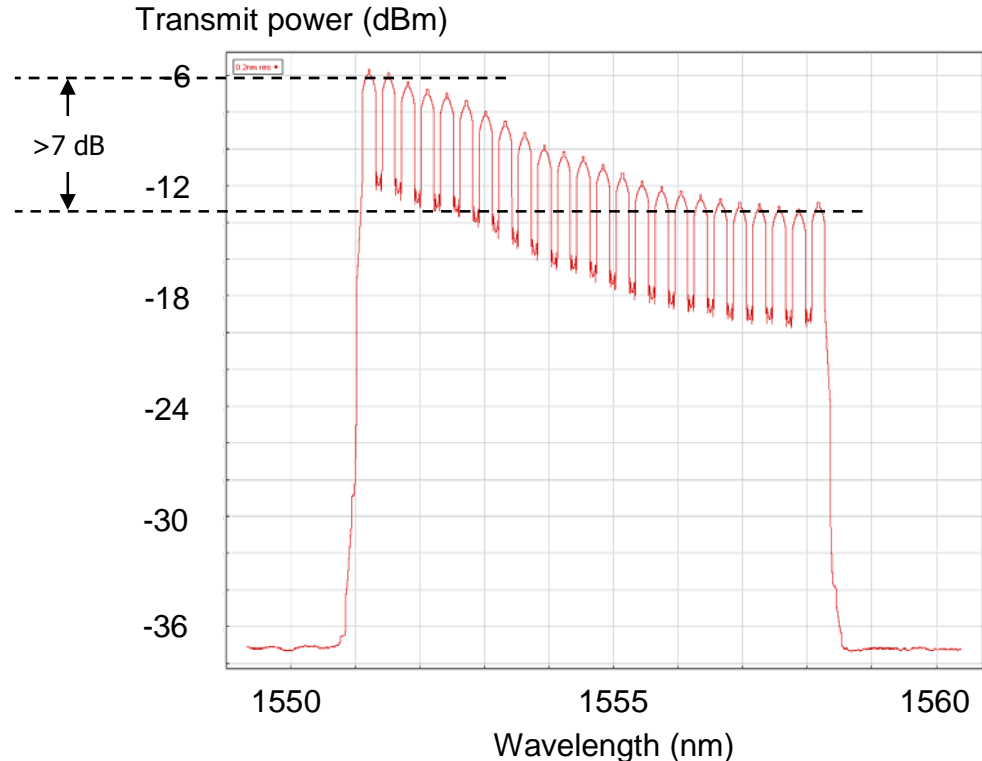

Migrating traffic

- A completely full system cannot be upgraded, without loss of traffic

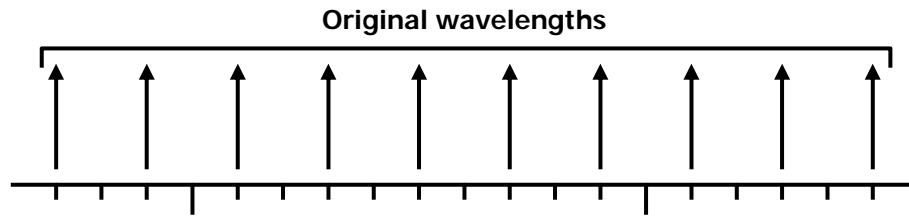

- Even *a little* headroom helps

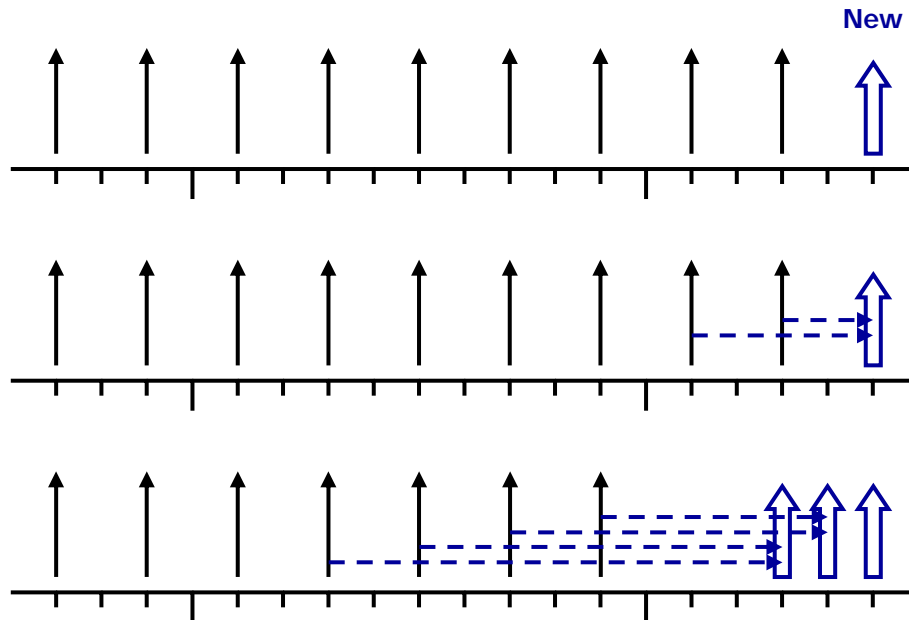

Amplitude v. Phase Shift Keying

- ASK

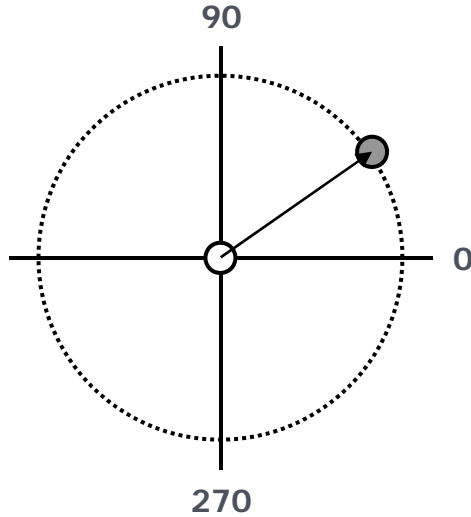

- PSK

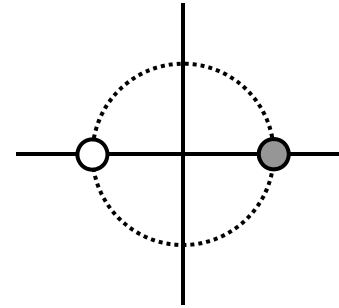

3 dB better

- QPSK

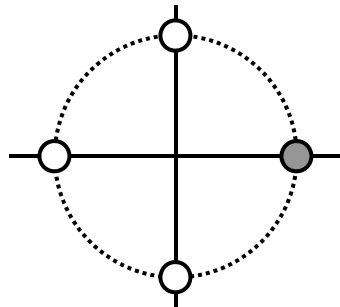

Needs more power, but transmits 2x the capacity

- Dual polarisation, BPSK / QPSK

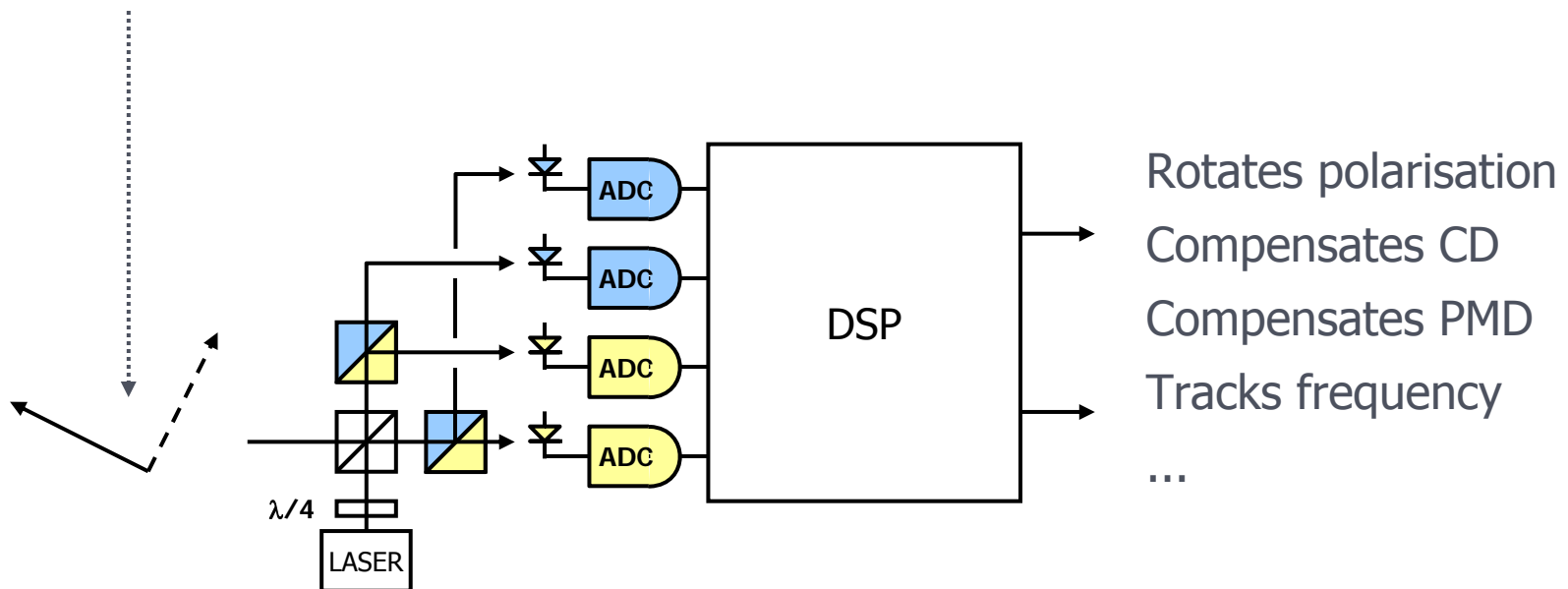

- ADC produces multi-level signal ideal for Soft-Decision FEC
- Can also do processing to mitigate non-linear effects

Forward Error Correction



- So far all systems have used hard-decision FEC

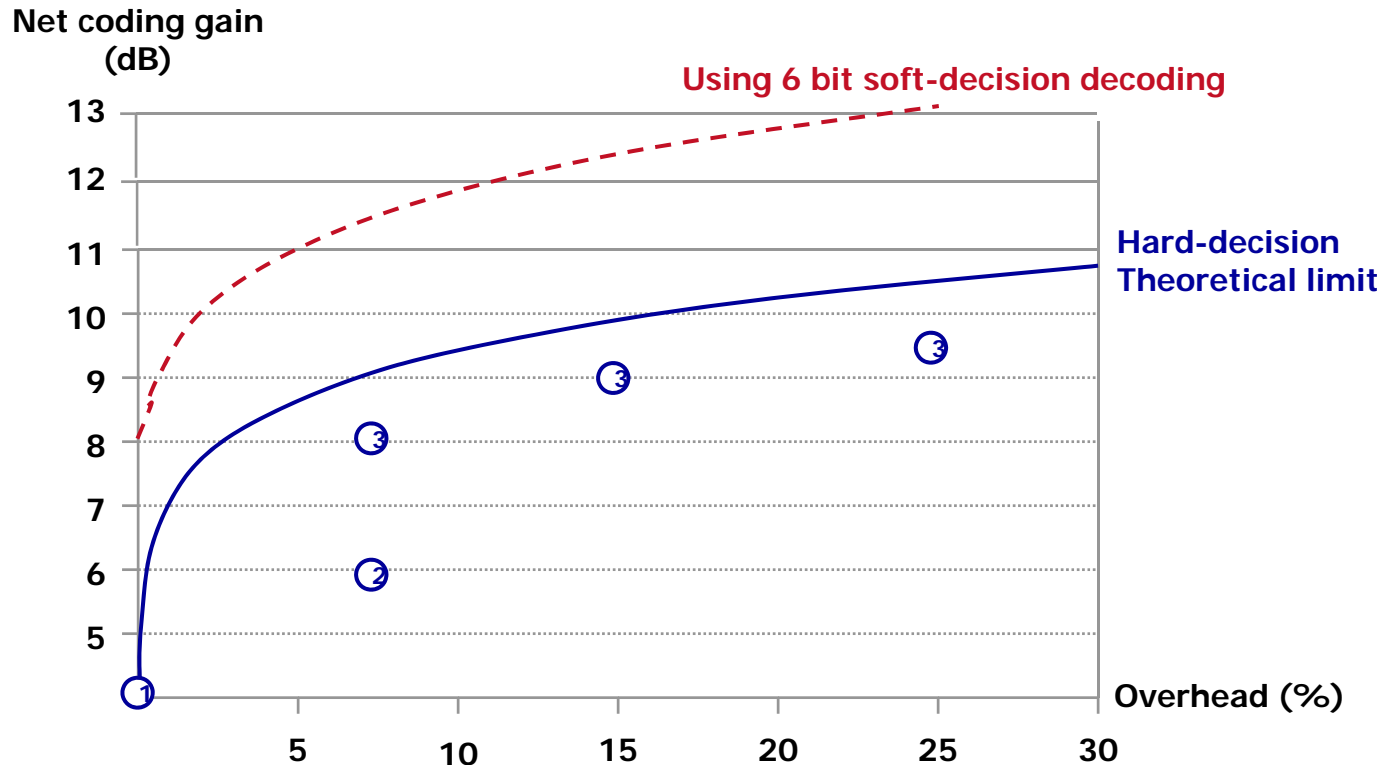

- Soft-decision FEC could be the next significant step – maybe >2 dB?



Soft decision – simple example

- 15 bit Hamming code with 4 parity bits, can correct 1 error; Fails with 2 errors

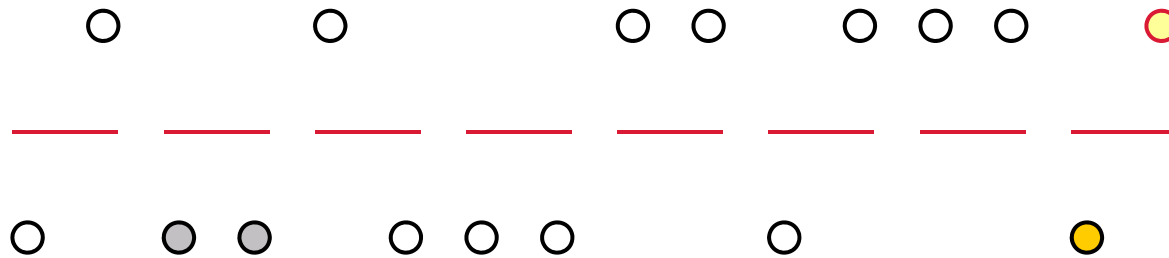

- Adding just one extra parity bit detects overload
- Identifies possible error pairs
- Actual values help locate the likely position of the errors

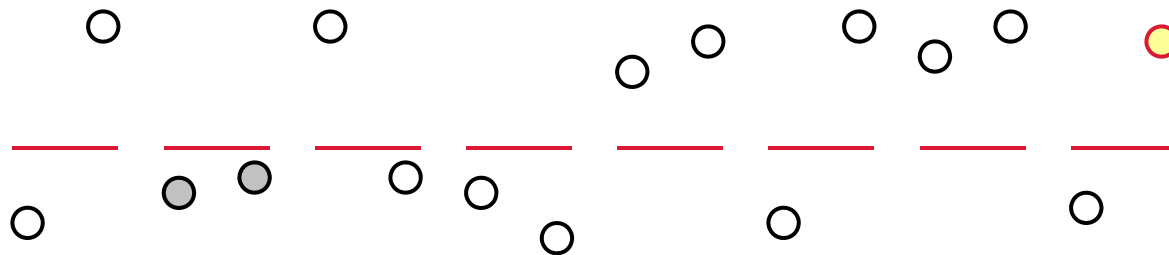

Terminal Technology Evolution

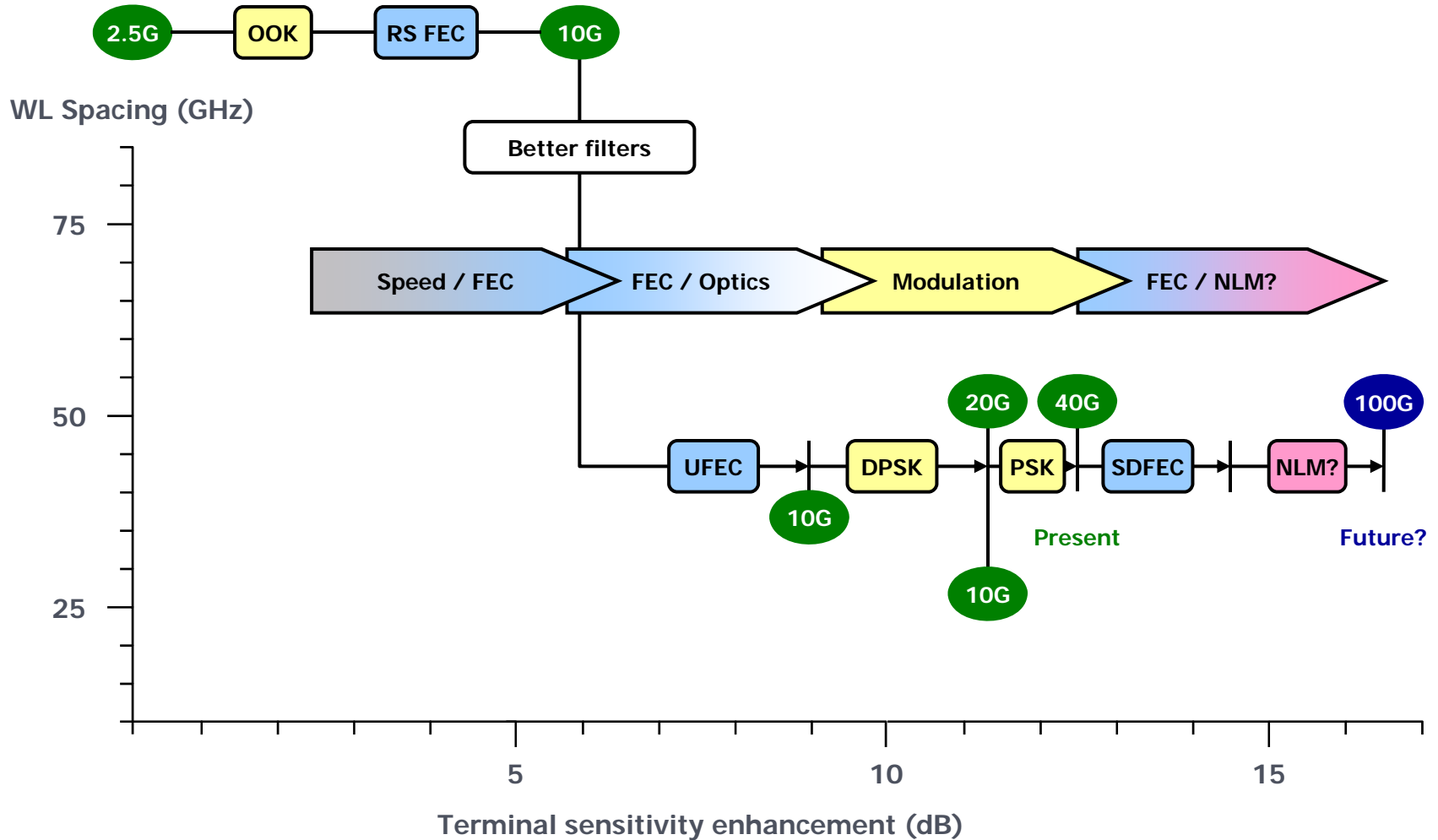

- Upgrades offer quick, low cost capacity increases
- Compared with a new build they have different issues to solve
- The technology is still evolving ...
even more capacity in the future



XTERA®

Maximizing Network Capacity, Reach and Value
Over land, under sea, worldwide