



# 100G + Raman Simplifies the Deployment of Terabit Networks



## Introduction

With the surge of bandwidth demands and development of bandwidth-hungry applications, there is a new pressure to maximize the capacity that can be transported by optical backbone networks in order to feed both business and residential customers.

As always, the objective is to increase the capacity in a cost-effective way (lower cost per bit) over the existing fiber plant. Since the advent of the first long-haul transoceanic submarine cable systems in the mid-90s, the specifications of optical fiber have been better understood and refined with characteristics enabling the multiplexing of multiple optical channels, each carrying a client signal, and the transport over ultra long-haul distances. Optical cables deployed after 1994 are generally compatible with transport of optical channels at rates of 40 or 100 Gb/s, with some fibers more conducive than others to very high line capacity.

While the channel rate has experienced a continuous growth from 2.5 to 40 Gb/s between the mid-90s and the end of the 10s, the optical amplification, that is required for an efficient long-distance transport of all the channels, has been mostly limited to the use of Erbium-

Doped Fiber Amplifiers (EDFAs). Although effectively enabling multi-channel amplification and transmission, the optical bandwidth of EDFAs is intrinsically limited to less than 40 nm, offering room for less than 100 optical channels (a typical figure in today's conventional transport systems is 88 optical channels).

Furthermore the noise performance of EDFAs is not optimal, resulting in a noise accumulation along the optical path with multiple in-line amplifiers. This noise accumulation degrades the Optical Signal-to-Noise Ratio (OSNR) experienced by the optical channels and is often a limitation in the optical reach, and/or channel count and/or channel rate.

Lastly the discrete nature of EDF amplification (i.e. the optical amplification happens at discrete "hot" spots along the optical path) is conducive to high nonlinear effects. These nonlinear effects, occurring inside the line fiber, are all the more important that the optical spans, limited by two optical amplification sites, are long or numerous (nonlinear effects also accumulate with the transmission length and the number of intermediate optical amplification sites). Similarly to noise accumulation, nonlinear effects can impose an upper limit upon the [Optical reach x Channel count x Channel rate] metric.

Both optical noise and nonlinear effects produce more and more stringent restrictions for channel count and optical reach when the individual channel rate increases.

Raman optical amplification offers an effective approach to mitigate the degradations brought by optical noise and nonlinear effects for all the channel rates. Actually Raman optical amplification was recognized, by 2008, by the optical community as technology of choice for 100G on performance and economics.

## Original Motivations to Develop all-Raman WDM Transport Systems

The Raman effect is a distributed nonlinear effect occurring along the optical fiber, whatever line fiber or specialty fiber. A strong optical wave (called the Raman pump wave or Raman pump source) is launched into the line fiber and interacts with the silica molecules found in the core of the optical fiber to create optical gain. In the 1.5- $\mu\text{m}$  spectral area, the optical gain created by Raman effect is centered at about 100 nm (one tenth of micrometer –  $\mu\text{m}$ ) above the Raman pump wavelength as illustrated in the Figure below. The Raman gain caused by a Raman pump source is not limited to a spectral line but spreads on either side of the peak gain wavelength and shows a significant optical bandwidth.

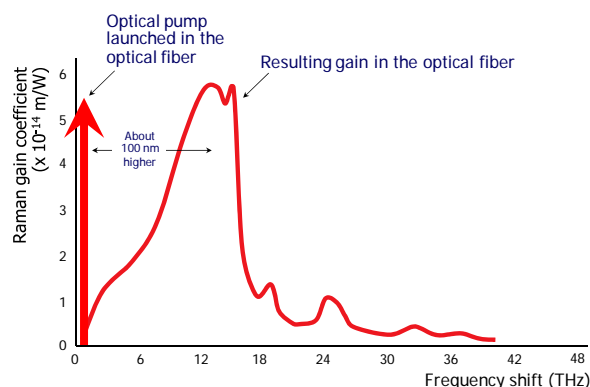

**Figure:** Spectral gain curve caused by optical pump launched into a piece of optical fiber via Raman effect.

The simultaneous launching of multiple Raman pump waves at different optical wavelengths allows combining the spectral gain contribution from each of the pumps. The result is a composite spectral gain profile which can offer an optical bandwidth as large as 100 nm.

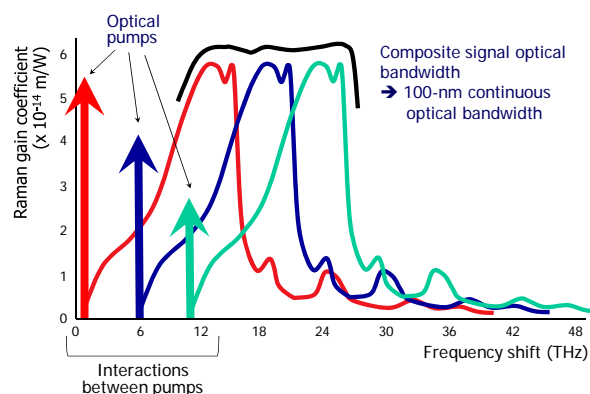

**Figure:** Composite spectral gain curve caused by multiple optical pumps launched into a piece of optical fiber via Raman effect.

Such a huge optical bandwidth allows the multiplexing of 240 optical wavelengths with standard channel spacing of 50 GHz (about 0.4 nm in the 1.5- $\mu$ m window) while more conventional EDFA-based amplifiers can accommodate typically 88 wavelengths. Using simple 10G transponder technology (with Non Return to Zero – NRZ – modulation format and small-overhead Forward Error Correction – FEC) line capacity can reach 2.4 T/s per fiber pair. This capacity achievement is one illustration of the benefits operators can get from high-end common equipment (i.e. in-line amplifiers): relaxing the specifications and requirements for the line interface cards, and minimizing the cost of the terminal equipment (line terminal equipment or Reconfigurable Optical Add Drop Multiplexer – ROADM). Exceeding the Terabit barrier was thus made possible by 2004, implementing simple and widely-available 10-Gb/s technology.

## Noise Performance

Beyond the unrivaled optical bandwidth, Raman amplifiers offer a superior noise performance compared to the one from EDFAs. The noise performance is a key parameter for optical transport over long distances: each modulation format and channel rate can properly transmit data only if the optical channel exhibits at the output end of the link a minimum OSNR. Because of its lower noise factor, a chain of Raman amplifiers will accumulate a smaller amount of optical noise compared to an EDFA chain; this smaller amount of accumulated noise limits the degradation of the OSNR at the receive end of the optical path.

Generally speaking the minimal OSNR required at the output end increases when the channel rate is increased. New modulation format and technology (e.g. phase modulation and coherent detection) can help reduce the increase in the OSNR that may be required when the channel rate is increased. However selecting an optical amplification technology that delivers a low noise figure is always a good future-proof approach to support higher channel rates in the long term with the same common equipment.

## Nonlinear Effects

Another great benefit of Raman amplification is the better control of the peak-to-peak excursion of the per channel optical power along the link. A smaller power variation reduces the impact of nonlinear effects on the integrity of the optical data that are transmitted.

Nonlinear effects in silica optical fiber are caused by the Kerr effect. The Kerr effect describes the dependency of the refractive index of the optical waveguide on the instantaneous optical intensity. This dependency is described by the relationship below:

$$n = n_0 + n_2 \times \frac{P(t)}{A_{\text{eff}}}$$

Where:

- $n_2 = 2.7 \times 10^{-20} \text{ m}^2/\text{W}$  (Kerr coefficient for silica material)
- $A_{\text{eff}}$  = effective area
  - Up to  $85 \mu\text{m}^2$  for G.652 fibers
  - $\approx 50 \mu\text{m}^2$  for G.653 fibers
  - Up to  $110 \mu\text{m}^2$  for G.654-like fibers
  - $50$  to  $80 \mu\text{m}^2$  for G.655 fibers

An optical fiber is a transmission medium that intrinsically favors nonlinear effects because of the small core area (leading to high intensity for a given optical power launched into the fiber) and long transmission distance with, for long-haul applications, optical repeaters (the so-

called in-line amplifiers) that are periodically placed along the optical path. Due to their narrower pulses, high channel rates are less robust toward nonlinear effects than lower channel rates, hence the strong interest in minimizing the nonlinear effects to enable high design capacities.

### Conventional EDFA-Based Systems

In the case of a conventional EDFA-based transmission system, each repeater site is a hot point in the link, where the whole multiplex of channels is amplified to its maximal power figure before attenuation by the line fiber composing the span between two adjacent repeater sites. In this configuration the line fiber is passive in the way it only brings attenuation to the optical channels. On their side, the repeaters function is to amplify the optical channels so they can reach the following site at a power level sufficient to guarantee a correct OSNR performance for a proper detection of the data stream at the output end. However the repeaters cannot launch the optical channels in the fiber span with a too high power otherwise the optical channels would experience significant nonlinear effects that would degrade the optical pulses and data integrity.

As a result the optical channels experience very large peak-to-peak power excursion along the optical path, with a power boost at each “hot” spots made of EDFA repeaters. Because of the upper limit for per channel power set by nonlinear effects and the lower limit imposed by minimal OSNR requirement, the per channel optical power profile looks like the one described in the Figure below.

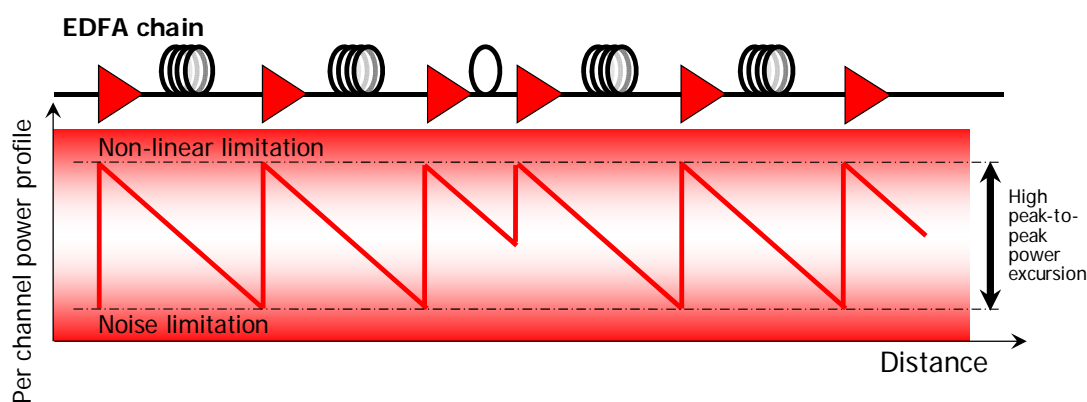

**Figure:** Typical per channel optical power profile as a function of the transmission distance in a chain of EDFA amplifiers.

Such a profile and such upper/lower limitations restrict the reach of EDFA-based transmission systems.

### Raman-Based Systems

The management of per channel power is quite different in an optical transmission system relying on Raman amplification. Here the line fiber is not only a transmission medium bringing optical attenuation to the optical channels but also a gain medium because of the

Raman amplification effect occurring inside the line fiber when Raman pump waves are launched into the fiber along with the optical channels supporting data.

In the backward Raman implementation, the Raman pumps are launched from the repeater site into the preceding fiber span, in a contra direction compared to the direction of transmission for optical channels.

In the forward Raman implementation, the Raman pumps are launched from the repeater site into the following fiber span, in the same direction as the direction of transmission for optical channels.

For very long spans (e.g. 250 km); Remote Optically Pumped Amplifiers (ROPAs) can be used. A ROPA is a sub-system that is typically placed 80 km before a repeater site. This sub-system is based on a few passive optical components that are placed inside an enclosure jointed to the cable. The typical passive optical devices found in a ROPA include specialty fibers, filters, and optical isolators. By nature, the ROPA is a fully passive sub-system that requires neither local electrical power, nor remote electrical power feeding from an active site. Furthermore this sub-system can operate in a wide range of temperature conditions, making unnecessary air conditioning.

The energy, required for generating optical amplification, is brought to the ROPA via optical way: the optical power of the Raman pump waves that are launched into the line fiber is used for both creating Raman gain in the line fiber and pumping the amplifying fiber found in the ROPA.

The figure below illustrates the evolution of the per channel optical power along a span where one ROPA has been inserted and pumped by the Raman pump sources launched from the in-line amplifier located at the end of the span.

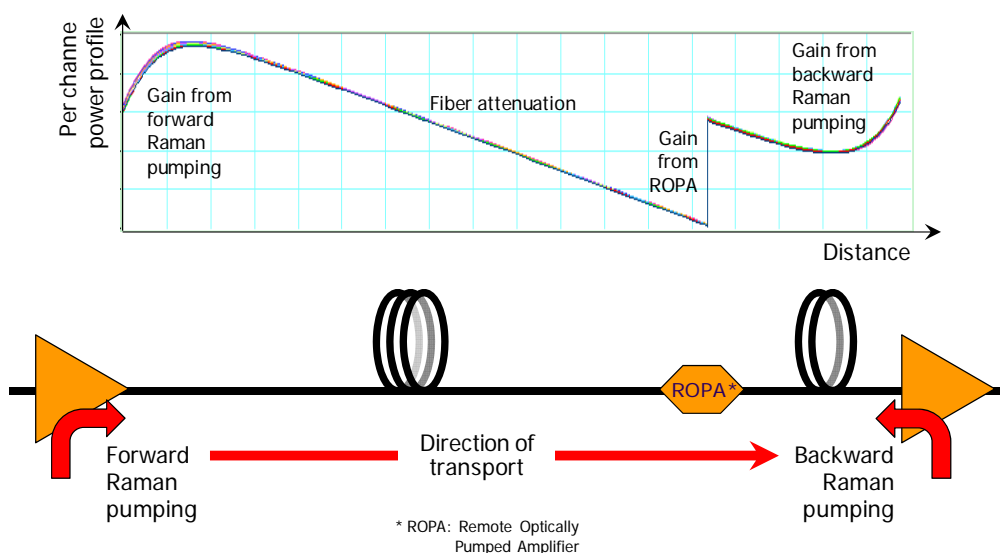

**Figure:** Per channel optical power profile as a function of the transmission distance along a fiber span between two in-line amplifiers where forward/backward Raman pumping and ROPA are implemented.

The figure below depicts the per channel optical power profile as a function of the transmission distance in a chain of Raman amplifiers. In order to efficiently cope with the various optical lengths (and attenuations) within optical networks, multiple Raman amplification approaches can be implemented:

- Discrete Raman amplification
- Forward distributed Raman amplification
- Backward distributed Raman amplification
- Remote Optically Pumped Amplifiers (ROPAs)

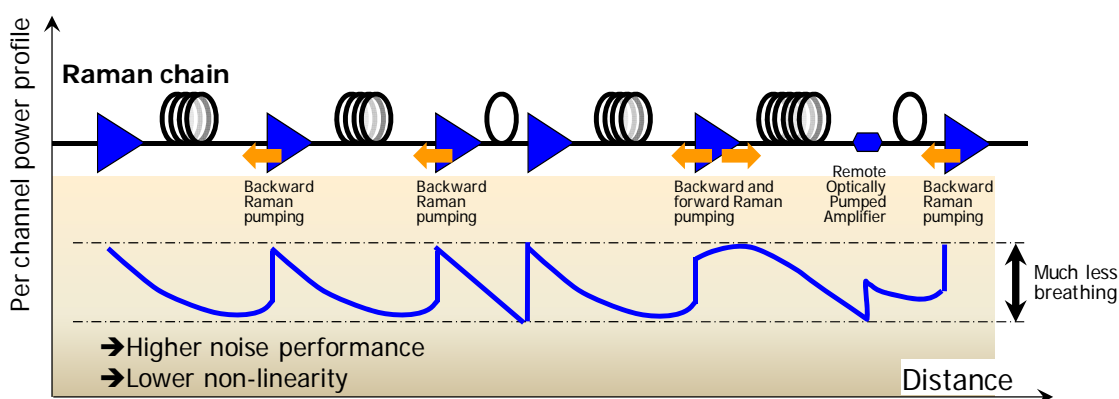

**Figure:** Typical per channel optical power profile as a function of the transmission distance in a chain of Raman amplifiers.

The net result is a lower peak-to-peak power excursion along the optical path compared to the EDFA chain and the capability to bridge longer spans.

The smaller breathing of the optical channel power results in less degradation due to nonlinear effects. On the other hand the superior noise performance from Raman amplification results in better OSNR performance at the output end.

### Optical synthesizer

The spectral gain profile can be dynamically adjusted by tuning the optical power of each Raman pump wave. This spectral flexibility, which is not offered by EDFA amplifiers, makes a Raman amplifier a true optical synthesizer and is extremely useful for optimizing the OSNR performance of the whole multiplex of channels across the optical bandwidth and extending at the most the reach.

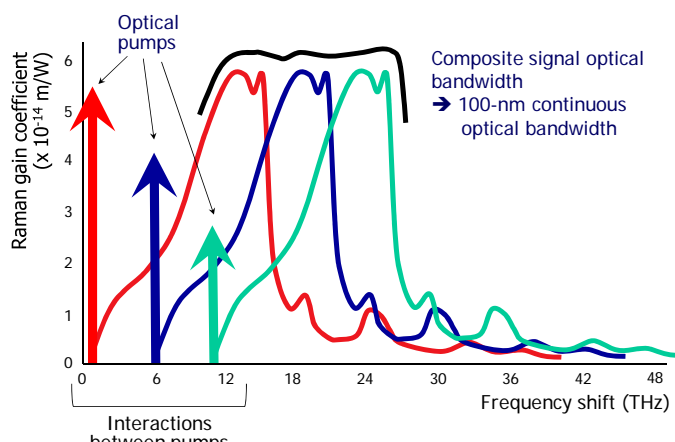

**Figure:** Raman amplifier as an optical synthesizer.

### Achievements of Raman amplification

The tremendous increase in [Capacity x Reach] metric offered by Raman amplification was demonstrated with the 2005 field trial conducted by Verizon Business and Xtera Communications in the US. 10- and 40-Gb/s channels were transmitted on a 3,040-km link made of optical cables installed in Verizon Business optical fiber plant and Raman in-line amplifiers. For every 80-km span made of standard G.652 fiber, the span loss was about 21 dB, including an average of 5 dB loss for connectors (corresponding to a fiber attenuation of 0.2 dB/km). No intermediate optical/electrical regeneration was used along this 3,040-km data path.

150 optical channels at 10 Gb/s can be transported on a 4,000-km optical path, still with no intermediate regeneration, and still with standard G.652 fiber. For unrepeated applications (typically to connect mainland with island), Raman amplification enables transport on more than 500-km distance with low-loss G.654 line fiber.

### **Raman Amplification by Xtera**

Based on a strong patent portfolio, Xtera Communications has developed a Raman amplification implementation based on the following toolkit:

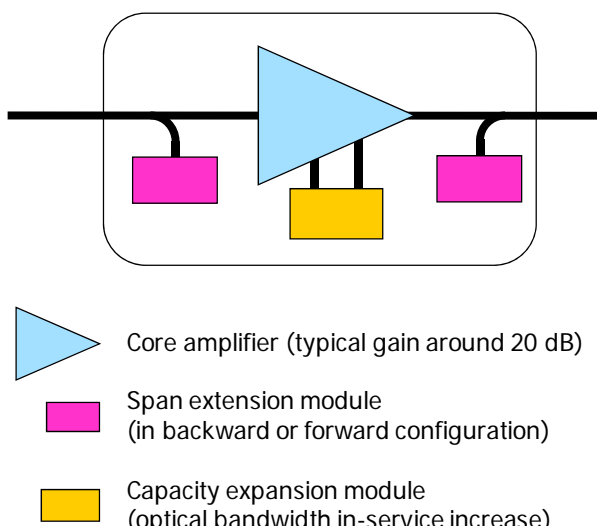

**Figure:** Toolkit for building composite Raman amplifiers.

The core amplifier relies on discrete Raman amplification (i.e. the Raman gain occurs not in the line fiber but in a specialty fiber located inside the core amplifier) and delivers a gain of typically 20 dB with an optical bandwidth of 25 nm. This modest bandwidth is built with a small number of Raman pump sources that are implemented in the core amplifier. The 25-nm optical bandwidth is suitable for Day-One capacity requirements with a limited number of optical channels put in service. A standard channel spacing of 50 GHz enables up to 60 optical channels (at 10, 40 or 100 Gb/s each) within this 25-nm bandwidth.

When more than 60 channels are required, the optical bandwidth can be widened by the adjunction of a capacity expansion module. Basically this capacity expansion module contains Raman pump sources at different wavelengths compared to the ones of the Raman pump sources built in the core amplifier. These new pump wavelengths create additional gain profiles that combine with the one of the core amplifier for building a 63-nm composite optical bandwidth. The connection of the capacity expansion module to the core amplifier is made in service, with no impact on the existing optical channels.

Moving back to the gain of the amplifier, the 20-dB gain offered by the core amplifier can accommodate spans with a typical length of 80 km. For significantly longer spans, the gain of the composite amplifier can be increased by adding span extension modules to the core amplifier. Different variants are available in order to cope for different span attenuations and the span extension modules can be implemented in backward and/or forward configuration.

This amplifier toolkit provides then flexibility along two axes:

- Span attenuation
- Optical bandwidth

One benefit of this 2-axes flexibility is illustrated in the two figures below.

- On Day-One, the amplifier bandwidth is set to 25 nm as the number of optical channels to be put in service at this time is usually smaller than 60. Gain wise span extension modules are added to the core amplifier in each amplification site depending on the actual attenuation of the span to be bridged. For small spans with

attenuation close to or smaller than 20 dB, only the core amplifier is implemented. For spans with attenuation exceeding 20 dB, span extension modules are inserted in the optical span as needed. Consequently the gain of each amplifier is tailored to fit the span distribution, avoiding the use of a single amplifier type which would be over-engineered for short spans.

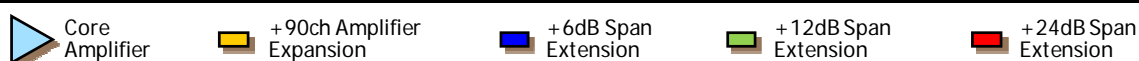
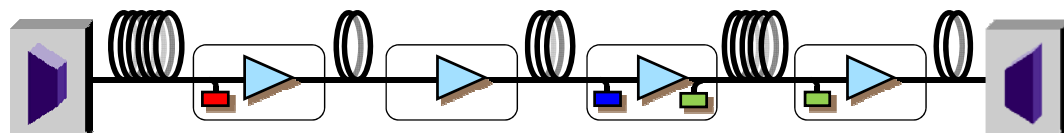

**Figure:** Day-One link configuration with 25-nm bandwidth (up to 60 optical channels).

- When more than 60 channels are required, the optical bandwidth is increased by simply connecting in service the capacity expansion module to the core amplifier module. In a point-to-point link, the capacity expansion module will be added to all the network elements. In a ring or meshed configuration, the capacity expansion module will be added only to the network elements on the segments where capacity needs exceed 60 channels.

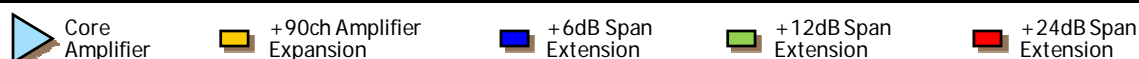
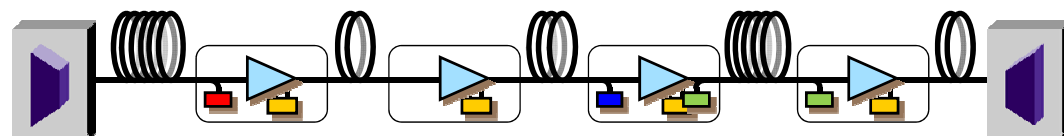

**Figure:** End-of-Life link configuration with 63-nm bandwidth (up to 150 optical channels).

The flexible configuration of the amplifier module is an ideal approach to optimize the configuration of the common line equipment depending on the actual network topology, physical network configuration and characteristics, and capacity requirements (on Day-One and in the long term).

For networks where the long-term requirements for channel count are significantly lower than 150, the core amplifier can be based on Erbium-doped fiber technology. In this case the number of optical channels is limited to 93 and cannot be of course increased in the future because the capacity expansion module mentioned above cannot operate.

## 100G by Xtera

### 100G drivers and benefits

The drivers for 100G transport can be simply summarized as follows:

- Maximization of fiber utilization
- Client equipment (typical example is routers) with 100G ports
- Minimization of cost of transport
- More power/space-efficient equipment

With a demand for high-bandwidth services and applications expected to increase at exponential rates, the primary driver for 100G introduction is clearly the quest for higher line capacity over the existing fiber plant. For instance, there are (in 2011) multiple routes in the core of pan-European networks that support today or will support at the yearend about 64 x 10 Gb/s of lit capacity. As 64 is the typical channel count of many transmission systems (the most recent ones supporting close to 90 channels), there is a clear need for increasing the capacity per channel for maximizing the line capacity. Obviously it is highly desirable that the introduction of 100G channel rate can be made via simply plugging new interface cards at the terminal or ROADM level without requiring any network re-engineering. In this perspective Raman amplifiers are by today the most future proof common equipment technology to enable simple migration from 10 to 100G channel rate.

Another driver which is likely to become significant by 2012 is the necessity to transport the optical signal delivered by 100G router interfaces. There were some attempts in the past to use inverse multiplexing (splitting a 100-Gb/s client signals onto ten optical channels at 10 Gb/s each) but this approach turned to be not cost effective.

Telecom operators have to face with a continuous pressure to reduce the cost per bit transported. This cost reduction is made mandatory not only by the will to maximize profit but also by the fact that the revenues per bit are strongly decreasing with the generalization of free contents and services. The resulting revenue pressure places a very strong pressure on the CapEx.

Lastly the above revenue pressure obviously produces a very strong demand for decreasing also the OpEx. Smaller-dimension and more power-effective equipment are an effective way to reduce the OpEx.

Beyond the raw increase in line capacity, 100G technology brings the following benefits:

- Higher density per 10G equivalent: Xtera Communications solution offers a reduction factor for interface cards form factor of 3.
- Lower power consumption: the gain generally ranges from 25 to 50%.
- Price efficiency: for long-haul application, the price per 10G equivalent is close to the one offered with 10G transponders. It is expected that within the next two years, the price per 10G equivalent offered by 100G cards will be significantly lower than with 10G cards. Furthermore, additional price efficiency is found through the elimination

or reduction of a variety of network devices or sub-systems, such as chromatic dispersion and Polarization Mode Dispersion (PMD) compensators.

## Overview of 100G technology

Unlike the 40G developments where multiple formats were assessed and proposed (NRZ, ODB/PSBT, CSRZ, ADPSK, DBPSK, DQPSK...), it seems that 100G development is avoiding the multiple modulation formats “mistake” of 40G.

There is a general consensus (e.g. from ITU-T and IEEE standardization bodies) around PM (or DP)-QPSK modulation format with coherent detection (PM: Polarization Multiplexing, DP: Dual Polarization, QPSK: Quadrature Phase Shift Keying). Almost all the equipment vendors, with the exception of a very few of them, are proposing this approach for enabling 100G channel rate.

On its side, the Optical Internetworking Forum (OIF) approved 100G coherent receiver Implementation Agreement (IA) in May 2010. The “*100G Ultra Long Haul DWDM Framework Document*” published by OIF provides a high-level description of PM-QPSK modulation format and associated 100G transmitter and digital coherent receiver design, as well as the rationale for this choice.

The basic principle of PM-QPSK modulation format is to trade speed for parallelism at the expense of added complexity, as illustrated in the Figure below.

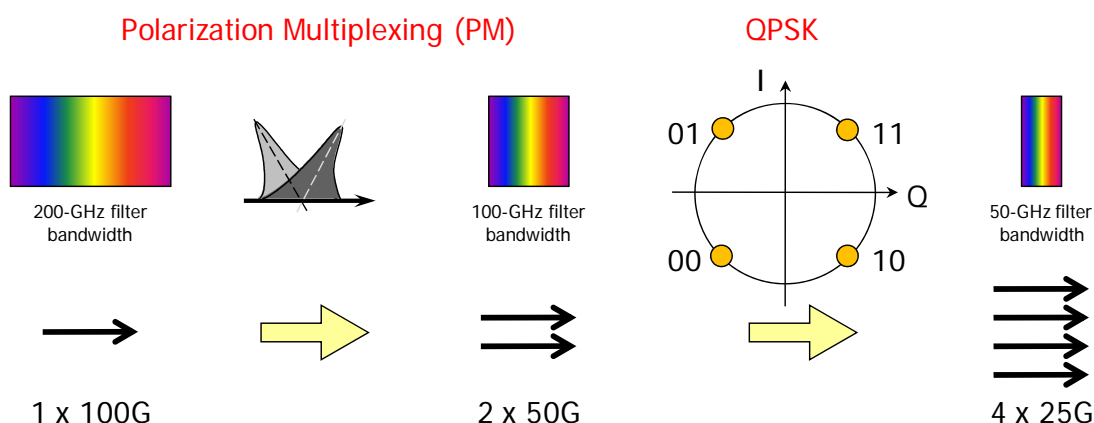

**Figure:** Principle of PM-QPSK modulation format.

Instead of modulating a single optical carrier at 100G using 100-Gb/s binary modulation format, two independent orthogonal states of optical polarization, at the very same optical frequency (because delivered by the same single laser source), are modulated. The polarization multiplexing halves the data rate, halves the spectral width, but doubles the count of components.

The next parallelism step is to encode the data to be transported not into 2 states like in any binary modulation format, but into 4-phase states. Consequently a single phase symbol

transports 2 bits of data. The quadrature phase shift keying halves the symbol rate compared to the binary phase shift keying. It also halves the spectral width but doubles the count of components.

The implementation of Quadrature Phase Shift Keying (QPSK) means that lab and field engineers need to move from conventional eye diagrams to constellation plots when one wants to quickly assess and measure the quality of signal.

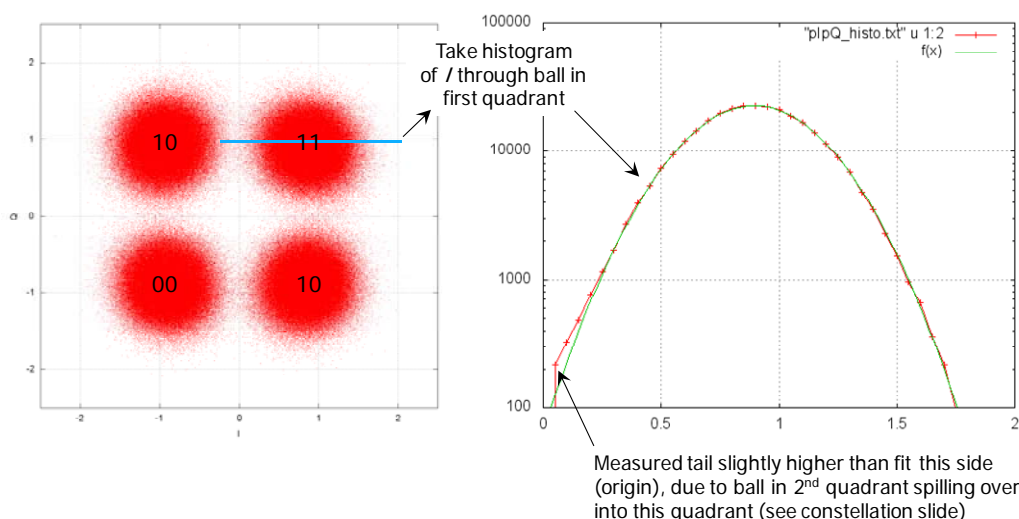
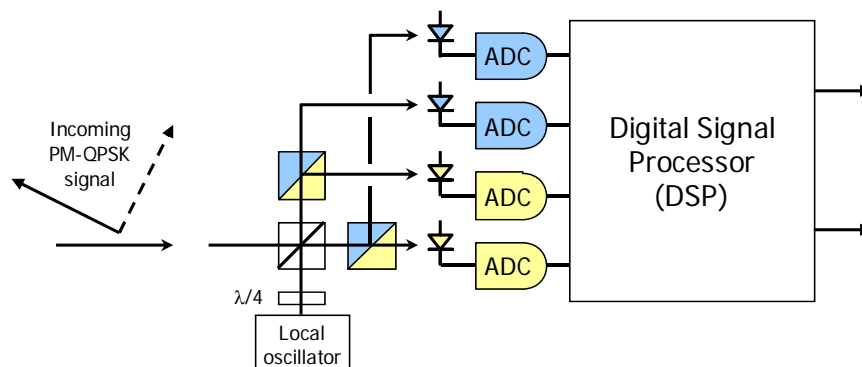

**Figure:** QPSK constellation plots on one of one the state of optical polarization for a PM-QPSK modulated signal.

The combination of dual polarization and QPSK reduces the required symbol rate by a factor of 4. To transport a 100-Gbit/s data stream, “only” 25 Giga of phase symbols (each encoded into 4-phase states) must be transmitted. We speak here of a symbol rate of 25 Gbaud/s for transporting a 100-Gbit/s data stream.

This approach allows the application of lower cost technologies when a lower symbol rate reduces the sensitivity of the signal to a number of optical propagation impairments.

At the output end, the received signal is mixed with a strong local oscillator (an optical laser source built in the 100G coherent receiver), generating mixing products at an intermediate frequency (i.e. the difference between the optical frequency of the received optical signal and the optical frequency of the local oscillator). The mixing products can be down converted and detected electronically. The analog components of the received signal are then digitized and fed to Digital Signal Processing (DSP) ASIC.



**Figure:** Synoptic of 100G digital coherent receiver for detection of PM-QPSK modulated signal.

The Analog to Digital Converters (ADCs) produce multi-level signal ideal for Soft-Decision Forward Error Correction (SD-FEC). The Digital Signal Processor (DSP) also compensates chromatic dispersion, Polarization Mode Dispersion (PMD) and frequency offset between the received signal and the local oscillator.

The main features of a digital coherent receiver are the higher OSNR tolerance and the full access to the electromagnetic field of the optical signal (i.e. amplitude and phase). On its side the standard receiver working with On/Off Amplitude Shift Keying (ASK) is able to recover only the power of the optical signal.

The full access to the electromagnetic field of the optical signal is key to allow digital equalization in the electrical domain of chromatic dispersion and Polarization Mode Dispersion (PMD). Accessing the amplitude and phase of the optical signal opens the path to multi-level amplitude and/or phase modulations (while the standard receiver working with On/Off Amplitude Shift Keying – ASK – could be implemented only with binary power modulation).

## 100G by Xtera

The basic principle of PM-QPSK modulation format described above is found in the 100G implementation selected by Xtera. The Figure below shows the long-haul 5”x7” Multi Source Agreement (MSA) module with management interface (Management Data Input/Output – MDIO) specified by OIF.

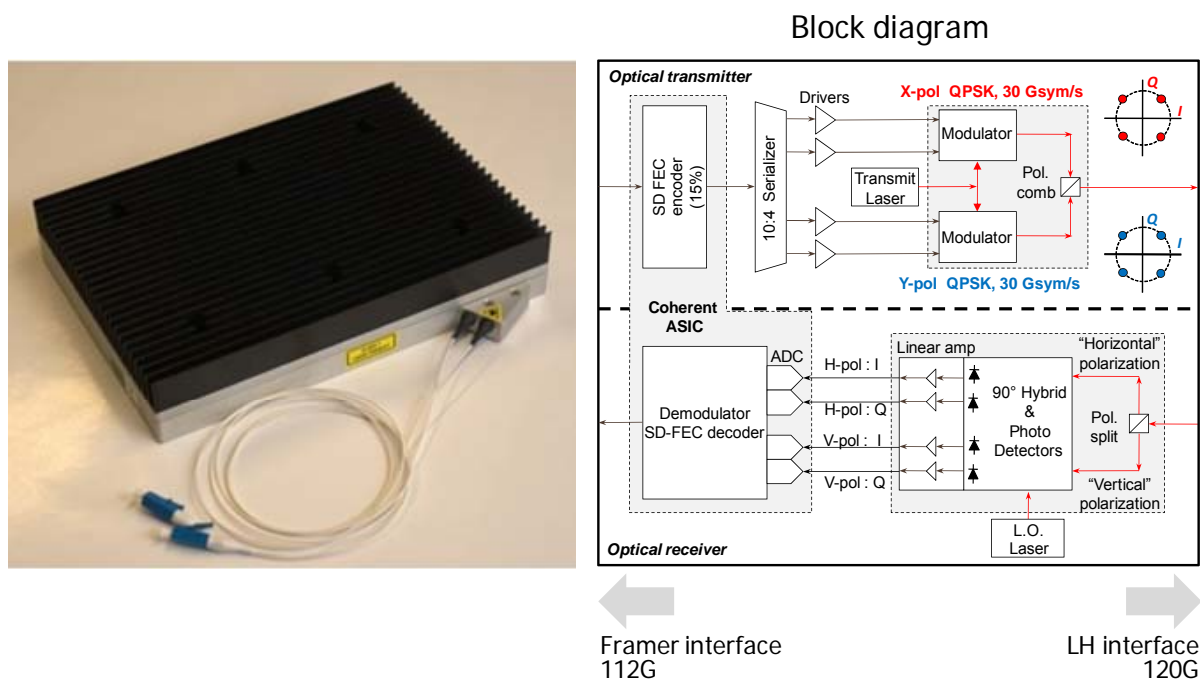

**Figure:** Long-haul 100G MSA module and block diagram.

On the right the block diagram shows the main components found inside the MSA module. In order to support 100 GbE client signal with the overhead necessary for OTN networking and forward error correction, the line rate is equivalent to 120 Gb/s.

The demodulator part includes the Digital Signal Processing (DSP) ASIC built around adaptive equalizers and adaptive algorithms. These components are the engines of the 100G digital coherent receiver for chromatic dispersion and Polarization Mode Dispersion (PMD) compensation.

40nm-CMOS technology is used inside Xtera Communications 100G digital coherent receiver, offering lower power consumption/dissipation and allowing Soft-Decision (SD) Forward Error Correction (FEC). Expressed as per 10G equivalent, 100G interface cards exhibit a power consumption/dissipation figure lower by 25 to 50% compared to a 10G interface card.

### Soft-Decision Forward Error Correction (SD-FEC)

So far all the codes used apply correction after the receiver has produced a one or zero based on whether the signal is above or below a threshold value. It is easy to calculate the gain for a perfect code of this type: the number of errors that can be corrected depends on the number of different parity checks that are performed. Increasing the number of checks adds to the overhead, but the graph below shows that increasing the overhead (and thus the complexity) of the code adds only small improvements. The squares show examples of actual codes that are used.

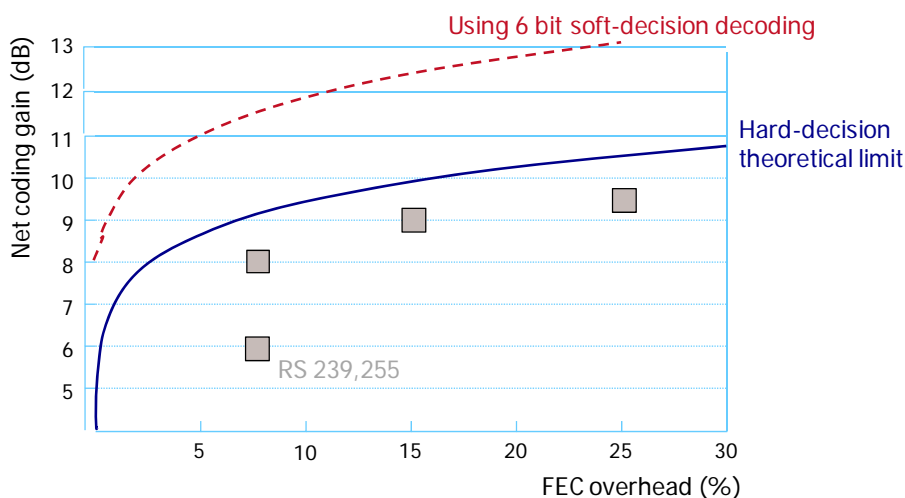

**Figure:** FEC gain vs. overhead.

Increasing the overhead also has the undesirable effect of increasing the line-rate and the spectral width of the signal.

A potential solution to this is the use of "soft-decision" correction, where the receiver no longer produced a stream of binary digits. Instead a very high speed Analogue to Digital Converter (ADC) produces a multi-bit signal which gives the amplitude of the detected signal.

This helps because a signal which is close to the decision threshold is more likely to be on the "wrong" side of it than one which is distant. With this extra information, and using appropriate coding and decoding, it is possible in theory to produce results 3 dB better than the binary process. Although the decoding process is extremely complex and requires ultra-high speed electronics, soft-decision solutions for 100G solutions offer significant advantages over binary hard-decision codes.

Practically net coding gain in the range of 1.5 to 2 dB is achieved today.

## 100G + Raman combination

Combining Xtera Communications technology for flexible Raman amplification and 100G long-haul interface cards, the line capacity can reach 15 Tb/s in the line fiber thanks to the wide optical Raman bandwidth accommodating up to 150 channels with standard 50-GHz channel spacing.

From a transport reach perspective, Raman amplification allows a better control of the longitudinal per channel optical power along the optical path, minimizing the impact of nonlinear effects on data transport. Although digital coherent receiver can bring a small

amount of nonlinear effect compensation, line equipment based on Raman amplifiers offers longer reach and smaller channel spacing compared to EDFA amplifiers.

A typical example is provided by link design for backhaul networks connecting cable landing stations to Points of Presence (PoPs). Up to 150 x 100G can be transported all-optically on 2,000 km, with no intermediate regeneration, with standard repeater spacing. This 15-Tb/s line capacity represents a 10-fold increase compared to what would be achieved with 10G optical channels.

Another illustration of the unique capabilities offered by Raman amplification is found with link designs for unrepeated applications. Xtera Communications demonstrated in 2010 the transmission of 8 channels at 100G each on an unrepeated distance of 444 km, with a Remote Optically Pumped Amplifier (ROPA) located about 110 km in front of the receive end. This 800-Gb/s line capacity is twice the line capacity that is obtained with 10G channels on the same unrepeated distance. With the current state of technology, it is not possible to transport more than 8 channels at 100 each because of the extremely high non linear effects that take place inside the line fiber when the optical channels need to span more than 400 km with no in-line amplifiers. Hence the smaller capacity benefit when moving from 10G to 100G channels compared to the terrestrial link with repeaters every 80 km.

Because of its highly nonlinear nature, this 444-km unrepeated link was an excellent test bed to assess whether 10G and 100G channels could be mixed and matched on a 50-GHz grid with no need for guard band between them. Tests clearly shown that 10G and 100G channels can be mixed with 50-GHz channel spacing, with no inter-channel degradation, even for high optical powers and gains in the link. Guaranteeing operation with 50-GHz channel spacing is obviously a crucial requirement to effectively raise total capacity of transmission systems when upgrading from 10G channels to 100G channels.

## Conclusion

In a context where commercial network operators forecast a long-term trend of traffic growth at rates of 50% per year or higher, the need for increasing the capacity of their core networks is more urgent than ever. One preferred way to achieve the network capacity increase is to move to 100G optical channel rates.

Raman amplification, in commercial services in backbone networks since 2004, has been field proven to offer the following features and benefits:

- Large optical bandwidth (up to 100 nm)
- Ultra long unrepeated links (up to 520 km with low-loss fiber)
- Unrivaled long regenerated sections in terrestrial networks
- Skipping of intermediate sites

Combined with 100G technology, the high-end Raman-based common equipment offers an ideal solution to optimize the 100G transport distance via superior noise performance and better control of nonlinear effects with a capacity in the line fiber up to 15 Tb/s.

## Glossary

Acronym	Meaning	Unit (If applicable)
ADC	Analog to Digital Converter	
ASK	Amplitude Shift Keying	
DP	Dual Polarization	
DSP	Digital Signal Processing	
IA	Implementation Agreement	
QPSK	Quadrature Phase Shift Keying	
EDFA	Erbium Doped Fiber Amplifier	
FEC	Forward Error Correction	
MDIO	Management Data Input/Output	
MSA	Multi Source Agreement	
NRZ	Non Return to Zero	
OIF	Optical Internetworking Forum	
OSNR	Optical Signal-to-Noise Ratio	dB / 0.1 nm
PM	Polarization Multiplexing	
PMD	Polarization Mode Dispersion	
SD-FEC	Soft-Decision Forward Error Correction	
WDM	Wavelength Division Multiplexing	



## **Maximizing Network Capacity, Reach and Value** *Over land, under sea, worldwide*

Edition Date: May 2011

Version: 1.0