

5400 OTP

Metro/Regional



5400 OTP

- Cost-effective in-line amplifier supporting up to 32 wavelengths – upgradeable to an OADM
- Companion product to the 6400 OTP
- Carrier-class design and reliability
- Flexible Client Service Interface Support
- ADM-on-a-wavelength® for efficient use of resources
- Automated network planning and management.

Cost-effective solution for metro core/regional networks requiring in-line amplification and low drop capacity OADM

5400 OTP (Optical Transport Platform)

The Meriton 5400 OTP provides a multi-service transport solution for network applications that do not require the high drop capacity of the full featured Meriton 6400 OTP. As a cost-effective alternative to the 6400 OTP, the 5400 OTP addresses low wavelength and low churn applications such as subtending spurs and nodes, and networks with reduced traffic demands, as well as in-line amplification. The 5400 OTP is optimized to transmit combinations of 2.5G and 10G signals on all fiber types.

The Meriton 5400 OTP includes optical amplifier modules for overcoming large span losses. It can be configured as an In-Line Amplifier (ILA) that can be upgraded to an OADM node with the addition of transponders and filter modules. In each case, as an ILA or OADM, the 5400 OTP uses variable gain amplifiers with automatic gain control and ultrafast transient suppression. No user intervention is required to adjust the amplifiers or power levels at any time. For spans requiring dispersion compensation, the amplifier modules in the 5400 OTP provide mid-stage amplifier access points for connecting dispersion compensation modules to the amplifiers.

As an OADM, the 5400 OTP is a 2-fiber ITU-T C-Band unidirectional WDM system that supports up to 32 express wavelengths per fiber in ring and linear network configurations, and allows up to 8 add/drop wavelengths.

Companion product to the 6400 OTP

The 5400 OTP was designed to perform in networks with 6400 OTP network elements, or with other 5400 OTP network elements, or combinations of the platforms. The platforms share the GMPLS control plane, many advanced automated optical layer features, and the same set of service interface cards (transponders). The GMPLS control plane and use of a 1510 nm Optical Supervisory Channel (OSC) allows the network elements to work as a fully automated system, and can be managed by the Meriton suite of management and network planning software.

Carrier-class design and reliability

The 5400 OTP is a carrier-class system and offers 99.999 percent availability and reliability. Like the 6400 OTP, the 5400 OTP has achieved extensive industry certifications, including NEBS level 3.



5400 OTP

Metro/Regional

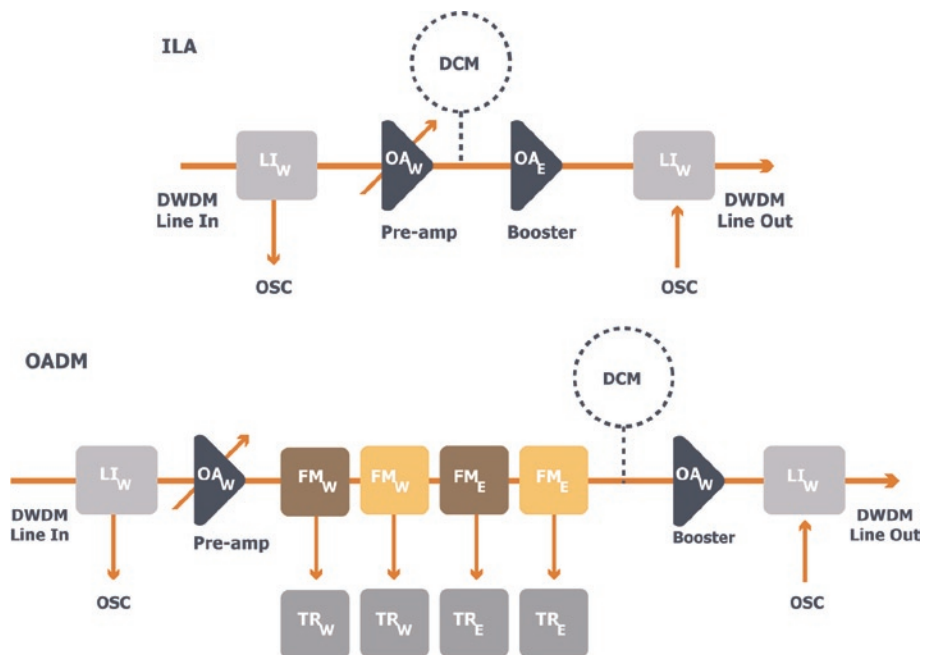

Flexible service support

To ensure its fit for a broad range of applications, the 5400 OTP supports a wide range of service protocols including Gigabit Ethernet (full and rate-limited) and 10GbE LAN/WAN PHY, Fiber Channel and FICON (1G and 2G), ESCON, DVB-ASI, protocol-independent (Any-rate) and SONET/SDH, including integrated SONET and SDH gateway functionality.

ADM-on-a-wavelength support

Like the 6400 OTP, the 5400 OTP provides the capability of transporting OC-48/STM-16 and OC-192/STM-64 signals transparently, with support for "traditional" SONET OC-3/12/48 and STM-1/4/16 add/drop multiplexing. The 5400 OTP also supports the high-density aggregation and transport of data services such as Gigabit Ethernet (full and rate-limited), ESCON, FICON (1G and 2G), Fiber Channel (1G and 2G), and DVB-ASI signals with the ADM-on-a-wavelength feature, offering significant bandwidth utilization efficiencies.

Automated network planning and management

Meriton's Agile Optical Networking product portfolio includes the Meriton 8500 EMS (Element Management System), the Meriton 8600 NMS (Network Management System), and the Meriton 9500 NPT (Network Planning Tool). In combination with the GMPLS-based control plane, the 8500 EMS offers powerful and flexible provisioning capabilities.

The Meriton 9500 NPT produces node equipment configurations based on span engineering data, cost optimization and traffic demands.

The intelligent Network Element system software is capable of quickly performing complex operations tasks such as an optical node add or delete, or an ADM segment add or delete, without interrupting protected traffic on the ring.

Using the 5400 OTP as an ILA or OADM

The diagram above illustrates the optical flow of traffic as it enters a 5400 OTP node. The signal entering the node first passes through the line interface (LI) pack. The LI pack removes the OSC and sends the OSC to the node controller for processing. The DWDM signals are directed to the OA, where the signals are amplified in a pre-amplifier. In an ILA application, the signals are then directed through an external dispersion compensating module (if needed), then onto the booster amplifier. At the output of the amplifier, the signals proceed to the outgoing LI where they are recombined with the outgoing OSC and transmitted to the next node.

In an OADM application, all express wavelengths follow the path just described, while drop wavelengths are dropped at the amplifier mid-stage point through Filter Modules (FM) and to their respective transponders (TR). Add wavelengths join the express DWDM signals also at the amplifier mid-stage.



Specifications

Applications

- OADM Nodes
- In-Line Amplifiers.

System capacity

- Total channels (express + add/drop): 32 Protected wavelengths, 64 unprotected wavelengths
- Add/Drop capacity – Node Total: 4 protected wavelengths, 8 unprotected wavelengths
- Add/Drop capacity – System Shelf: 2 protected wavelengths, 4 unprotected wavelengths
- Add/Drop capacity – Expansion Shelf: 2 protected wavelengths, 4 unprotected wavelengths.

Client interfaces

- OC-3/12/48/192, STM-1/4/16/64
- GbE, Rate-Limited GbE, 1000BaseT Electrical, 10GbE LAN/WAN
- Fibre Channel (1 and 2 Gb/s), FICON (1 and 2 Gb/s), ESCON
- DVB-ASI
- Any Rate 8 Mb/s to 2.55 Gb/s.

Protection

- Line Side
 - Optical Dedicated Protection
 - Optical Shared Protection
 - ADM-on-a-wavelength SONET UPSR/SDH SNCP
 - Unprotected
 - Link and Node Disjoint
- Client Side
 - SONET/SDH 1+1 Linear APS
 - 1x1 Splitter/Combiner Client Protection.

Topology

- Point-to-Point
- Linear
- Ring
- Logical Mesh.

Control plane network element software

- Based on GMPLS with RSVP, OSPF, and LMP
- Compatible with 6400 OTP.



5400 OTP

Metro/Regional

Americas

Corporate Headquarters

Xtera Communications - USA
500 W. Bethany Drive, Suite 100
Allen, TX 75013
USA

T +1 972 649 5000

F +1 972 747 0344

Europe

EMEA (UK)

Xtera Communications - UK
Bates House, Church Road
Harold Wood, Romford
Essex RM3 0SD
UK

T +44 (0) 8701 417 237

F +44 (0) 1708 335 425

Asia

Taiwan

Xtera Communications - Taiwan
4F, No.102
Guangfu S.Road
Da-an District
Taipei 10612
Taiwan

T +886 (0)2 6636 0550

F +886 (0)2 8772 2262

E info@xtera.com

www.xtera.com



Service multiplexing and ADM-on-a wavelength

- Up to 10 ports for OC-48/STM-16, OC-12/STM-4, OC-3/STM-1 client multiplexing into a 2.5G or 10G line rate
- Up to 10 ports for GbE, SAN and DVB-ASI multiplexed into ADM-on-a-wavelength 10G line rate
- ADM-on-a-wavelength allows wavelength to be provisioned to perform as a SONET/SDH ADM ring
- Each ADM ring can make use of a different set of nodes in the ring.

Optical

- System Transmission – any combination of 2.5G and 10G wavelengths
- Automatic gain control and ultra-fast, automated transient control
- Monitoring and power control on add wavelengths
- Full C-Band Tunable Lasers
- Amplification for up to 32 dB spans
- Mid-OA access for dispersion compensation.

SW management

- Craft Interface – CIT, CLI, TL1
- 8500 EMS
- Dual Gateway CORBA interface to EMS
- Optical Supervisory Channel – 1510 nm, 100Mb/s Ethernet
- Customer Data Channel – 10Mb/s Ethernet.

Optical layer configuration and traffic planning

- 9500 NPT (Network Planning Tool).

Environmental/compliance

- NEBS Level 3, UL, CE Mark, FCC Part 15 Class A, ETSI.

Availability

- 99.999% Availability; additional details available on request.

Mechanical

- System Shelf: 17.5" x 8.7" x 21.5" (WxHxD)
- Expansion Shelf: 17.5" x 8.7" x 21.5" (WxHxD)
- Mounting hardware for NEBS 2000/ETSI/Data Racks
- Weight – approx. 80 lbs. for fully loaded system shelf; approx. 50 lbs. as ILA.

Power input

- -48 VDC nominal, -40 to -60 VDC operating range
- Independent A and B feeds, independently fused.